

PLAN
NTS
TYPE "BELOW GRADE"

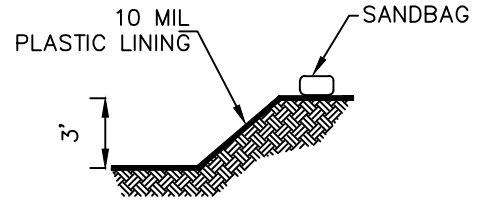

SECTION A-A
NTS

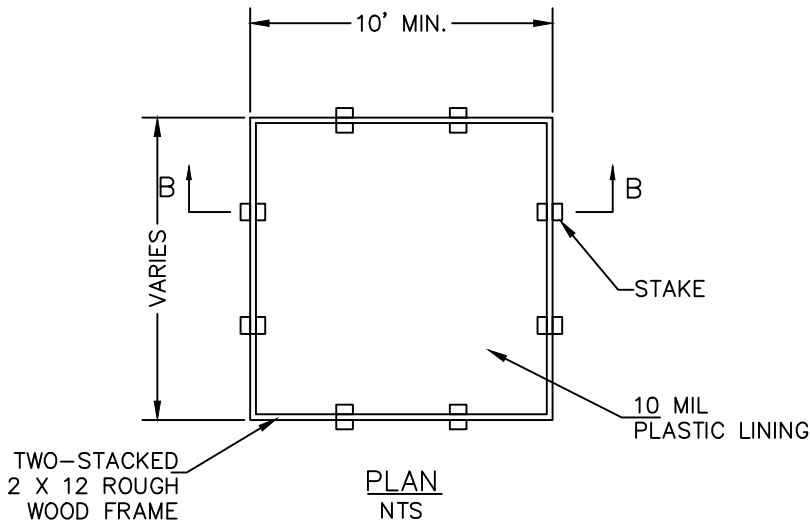

PLAN
NTS
TYPE "ABOVE GRADE"

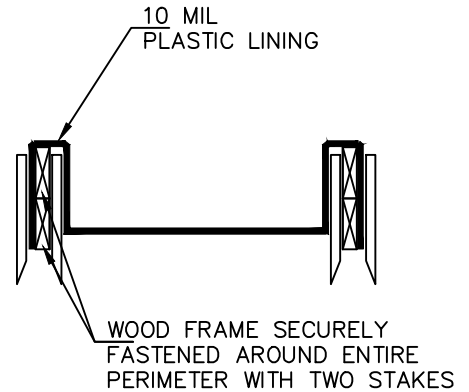

SECTION B-B
NTS

NOTES:

1. TEMPORARY CONCRETE WASHOUT FACILITIES SHOULD BE LOCATED A MINIMUM OF 50' FROM STORM DRAIN INLETS, OPEN DRAINAGE FACILITIES, AND WATER COURSES.
2. ACTUAL LAYOUT SHALL BE DETERMINED IN FIELD.
3. A SIGN SHOULD BE INSTALLED ADJACENT TO THE FACILITY TO INFORM CONCRETE EQUIPMENT OPERATORS TO USE THE PROPER FACILITIES.
4. THE CONCRETE WASHOUT SIGN SHALL BE INSTALLED WITHIN 30' OF THE TEMPORARY WASHOUT FACILITY.
5. ONCE CONCRETE WASTES ARE WASHED INTO THE DESIGNATED AREA AND ALLOWED TO HARDEN, THE CONCRETE SHOULD BE BROKEN UP, REMOVED, AND DISPOSED OF.
6. WASHOUT FACILITIES MUST BE CLEANED, OR NEW FACILITIES CONSTRUCTED AND READY FOR USE ONCE THE WASHOUT IS 75% FULL.



TOWN OF MOORESVILLE

STANDARD DETAIL

MISCELLANEOUS DETAILS
**TEMPORARY CONCRETE
WASHOUT FACILITY**

January 2009
Revision 1

NTS

M-2.0